

INSTALLATION & MAINTENANCE INSTRUCTIONS

DESCRIPTION

The QB3 is a closed loop pressure regulator consisting of two solenoid valves, internal pressure transducer, and electronic controls mounted to an integrated mechanical regulator. The pressure is controlled by activating the solenoid valves, which apply pressure to the pilot of the mechanical regulator. One valve functions as inlet control, the other as exhaust. The unit output pressure is measured by a pressure transducer, which is internally mounted to sense pressure in the work port of the QB3 and provides a transduced feedback signal to the electronic control circuit. This feedback signal is compared to the command signal. Differences between the command signal and the actual pressure feedback signal causes one of the solenoid valves to open to adjust the pressure in the pilot of the booster/regulator. Pilot pressure is adjusted so that desired down stream operating pressure is achieved and maintained. Because the working pressure is sensed as opposed to pilot pressure, hysteresis in the integrated mechanical regulator is eliminated.

The output pressure is proportional to an electrical command signal. Command inputs are either a differential 0-10 VDC or 4-20 mA. The unit comes standard with an electrical monitor signal for tracking pressure which comes from the internal pressure transducer.

The uniqueness of the booster design is that it has no stamped gaskets or special molded diaphragm or seal parts. All of the parts related to normal maintenance are standard O-rings.

PNEUMATIC CONNECTIONS

CAUTION: USE ONLY THE THREAD SEALANT PROVIDED. OTHER SEALANTS SUCH AS PTFE TAPE AND PIPE DOPE CAN MIGRATE INTO THE FLUID SYSTEM CAUSING FAILURES.

1. The valve can be mounted in any position without affecting performance. Mounting brackets (ordered separately) can be used to attach valve to a panel or wall surface.
2. A typical 40 micron in-line filter is recommended on the inlet of the QB3 valve.
3. Connect supply pressure to the **I** port (Figure 1) not to exceed rated supply pressure. (See TABLE 1)
4. Connect the **O** port (Figure 1) to the device being controlled.
5. **If this is a vacuum or vacuum through positive pressure unit, connect vacuum supply to E exhaust port. Positive pressure is required on the inlet with vacuum units. FOR ANY QUESTIONS, PLEASE CALL THE FACTORY.**
6. For positive pressure only units the **E** exhaust port can be plumbed to a point outside the work area, fitted with a muffler or left open to atmosphere as the application dictates.
7. Proceed with electrical connection.
8. For low-pressure QB3 units, the unit must be mounted upright to ensure proper functionality.

Before you get started, please read these warnings

- ◆ Examine the product. Ensure that you received what you ordered.
- ◆ Read this guide first before you start and save it for later use.
- ◆ You must have a good understanding of what the adjustments are on this product before using them.
- ◆ All compressed air and power should be shut off before installing, removing or performing maintenance on this product.
- ◆ Installation and use of this product should be under the supervision and control of properly qualified personnel in order to avoid the risk of injury or death.



CE (EMC) Compliant

Except for models having the following features: RS232, RS485, P2 Profiler and Digital Display



QB3 with digital display option shown

SPECIFICATIONS

ELECTRICAL

SUPPLY VOLTAGE	15-24 VDC
SUPPLY CURRENT	250 mA
COMMAND SIGNAL	0-10 VDC 4-20 mA
COMMAND SIGNAL IMPEDANCE	VDC = 10 KΩ Current = 100 Ω
VOLTAGE MONITOR SIGNAL	0-10 VDC @ 20 mA max
CURRENT MONITOR SIGNAL	4-20 mA Sinking (sourcing opt)

MECHANICAL

PRESSURE RANGES	Full Vacuum - 150 psig (760 mmHg (Vac) - 10.3 Bar)
OUTPUT PRESSURE†	0-100% of range
FLOW RATE	30 SCFM @ 110 psig supply & 80 psig output (850 L/min @ 5.5 Bar)
PORT SIZE	1/4" NPT
Min CLOSED END VOLUME	3 in ³
FILTRATION RECOMMENDED	40 Micron
LINEARITY/HYSTERESIS	<±0.3% F.S. BFSL
ACCURACY	<±0.25% F.S.
WETTED PARTS ‡	
ELASTOMERS	Buna N
MANIFOLD	Aluminum Nickel Plated
VALVES	Nickel Plated Brass or 400 Series Stainless Steel
PRESSURE TRANSDUCER	Utem 1000, Aluminum

PHYSICAL

OPERATING TEMPERATURE	32-158°F (0-70°C)
WEIGHT	1.5 lbs. (0.68 kg)
PROTECTION RATING	NEMA 4
HOUSING	Aluminum (Anodized)

† Pressure ranges are customer specified. Output pressures other than 100% are available. ‡ Others available

QB3

ELECTRICAL CONNECTIONS

1. Turn off all power to valve.
2. Identify the valve's command input and analog output using the calibration card included in the package and the ordering information section on the last page of this sheet.
3. Proceed to the appropriate section corresponding to the type of valve being installed. Please refer to page 5 of this installation guide to identify input and monitor signal.

NOTE: ALL COLOR CODES RELATE TO QB3'S ORDERED FROM THE FACTORY WITH WIRE LEADS.

COMMAND SIGNAL CONFIGURATIONS

Voltage & Current Commanded (E, I, K, V)

All voltage command QB3's use a differential command. If a single ended voltage will be used, tie the command return wire to DC common. Current command also uses a differential loop where the command flow is from Pin 4 to Pin 2. Some applications may require the common of the device that provides loop power for the 4-20mA command to be tied to power supply common.

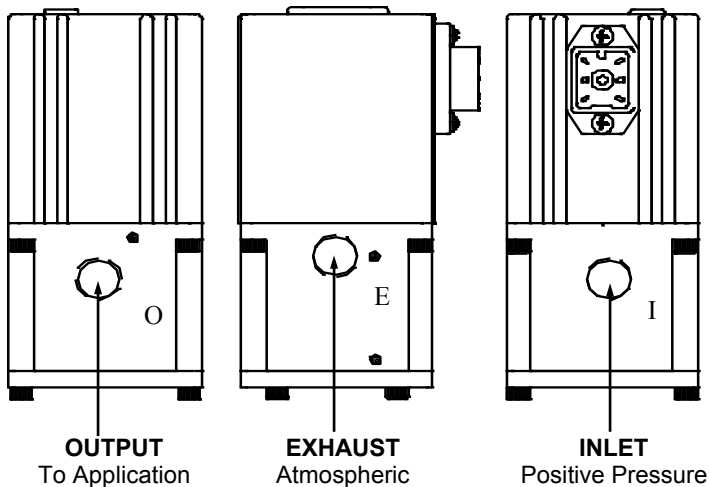
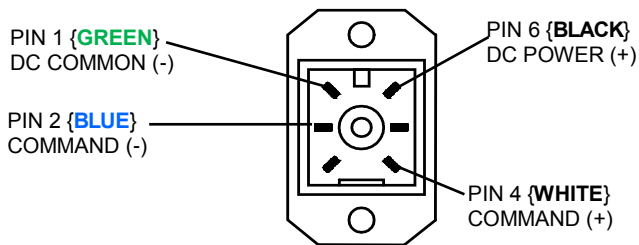
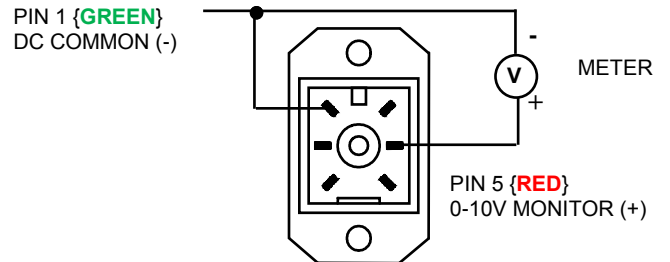

FIGURE 1

MONITOR SIGNAL CONFIGURATIONS

Voltage Monitor (E, K, V)



Current Sinking Monitor (C)

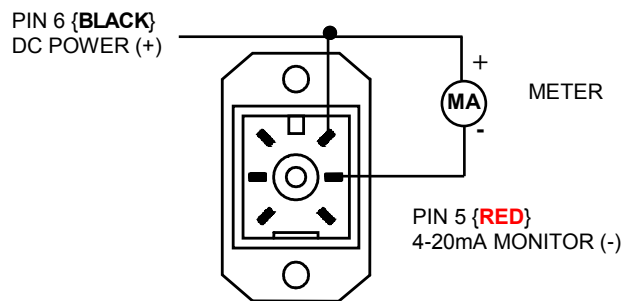

Current Sourcing Monitor (S)

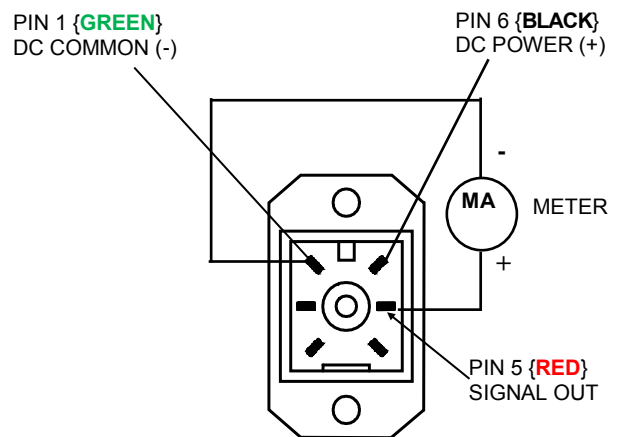

RE-CALIBRATION PROCEDURE:

All QB3 valves come pre-calibrated from the factory using precision calibration equipment. If the QB3 valve needs re-calibration, use the procedure described below:

1. Wire control valve according to the section titled "Electrical Connections."
2. Connect a precision measuring gauge or transducer to the outlet port of the QB3. **NOTE: THERE MUST BE A CLOSED VOLUME OF AT LEAST 5 CU. IN BETWEEN THE VALVE OUTLET AND THE MEASURING DEVICE FOR VALVE TO BE STABLE.**
3. Plumb control valve according to section titled "Pneumatic Connections". Make sure supply pressure does not exceed the rating for the valve (see table 1).
4. On the printed circuit board, locate the two adjustment potentiometers **SPAN** and **ZERO**. (See figure 2)
5. **ONLY USE THIS STEP IF DEVICE IS COMPLETELY OUT OF CALIBRATION. IF IT IS SLIGHTLY OUT OF CALIBRATION, PROCEED TO STEP 6.** With a small screwdriver, turn both potentiometers 15 turns clockwise. Then turn them 7 turns counter clockwise. This will put the QB3 roughly at mid scale
6. Set the electrical command input to MAXIMUM value.
7. Adjust the SPAN potentiometer until MAXIMUM desired pressure or vacuum is reached (clockwise to increase pressure).
8. Set the electrical command input to 10 percent of full value (1VDC for 0-10VDC unit or 5.6mA for 4-20mA unit).
9. Adjust the ZERO potentiometer until 10 percent of maximum desired pressure or vacuum is reached. (clockwise increases pressure).
10. If at any time during the calibration procedure the control valve oscillates or becomes unstable for more than one second, turn the hysteresis potentiometer counter-clockwise until the oscillation stops, then turn it one more complete turn (same direction).
11. The ZERO and SPAN potentiometers interact slightly. Repeat steps 5-10 until no error exists.
12. Verify unit shuts off by going to zero command. Check linearity by going to at least six pressure points throughout the full range.

TABLE 1

MAX. calibrated pressure: Max. inlet pressure:

Vacuum only	5 PSIG
Vacuum up to 10 PSIG	15 PSIG
10.1 up to 30 PSIG	35 PSIG
31 up to 100 PSIG	110 PSIG
101 up to 150 PSIG	165 PSIG

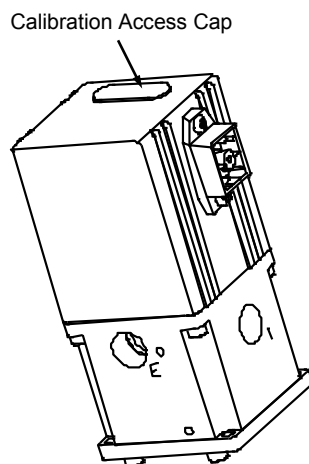
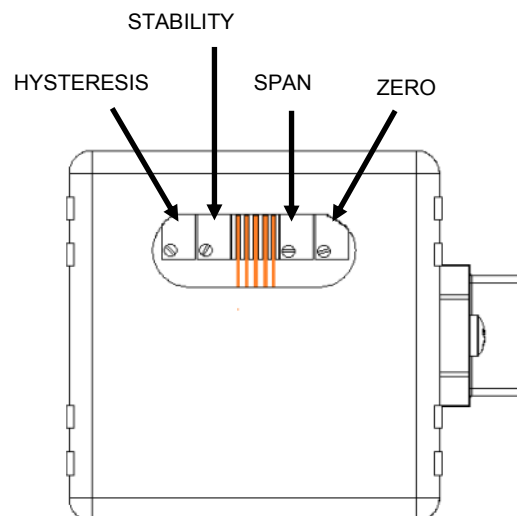
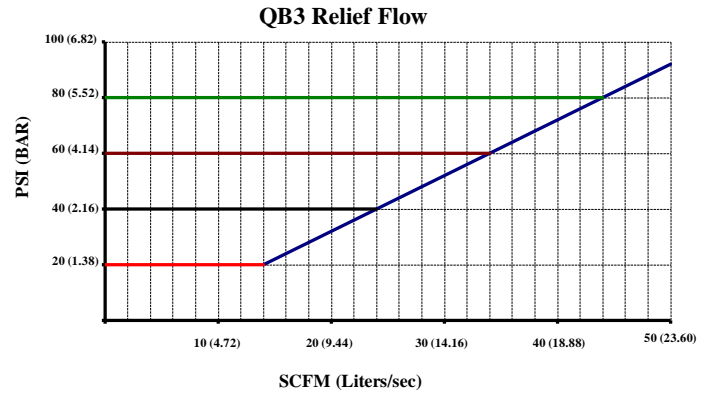
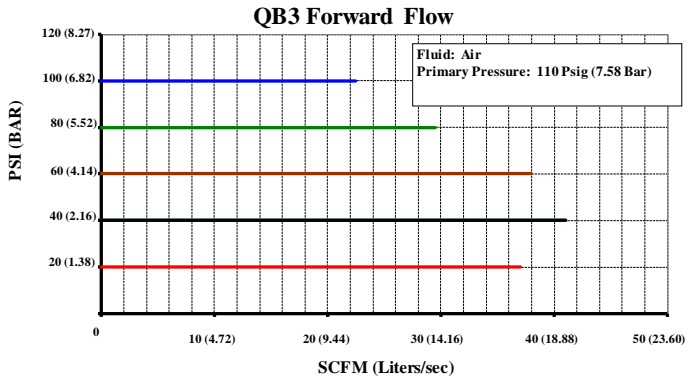
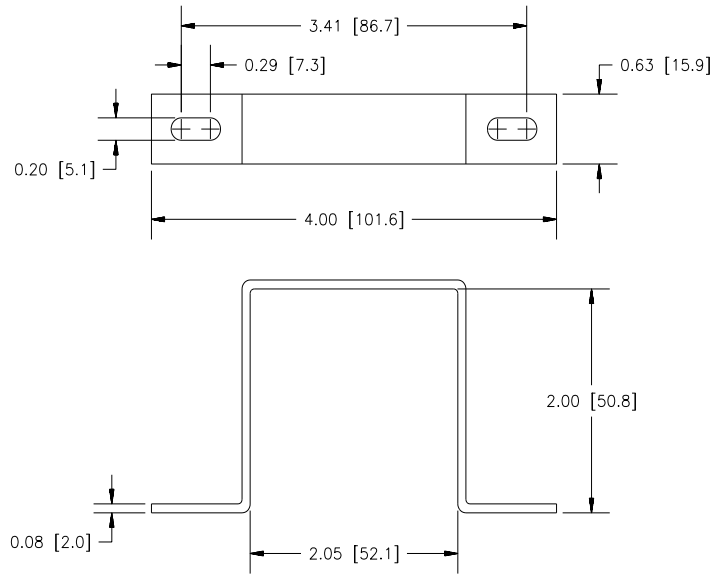

FIGURE 2





QBT-01 MOUNTING BRACKET



DIMENSIONS

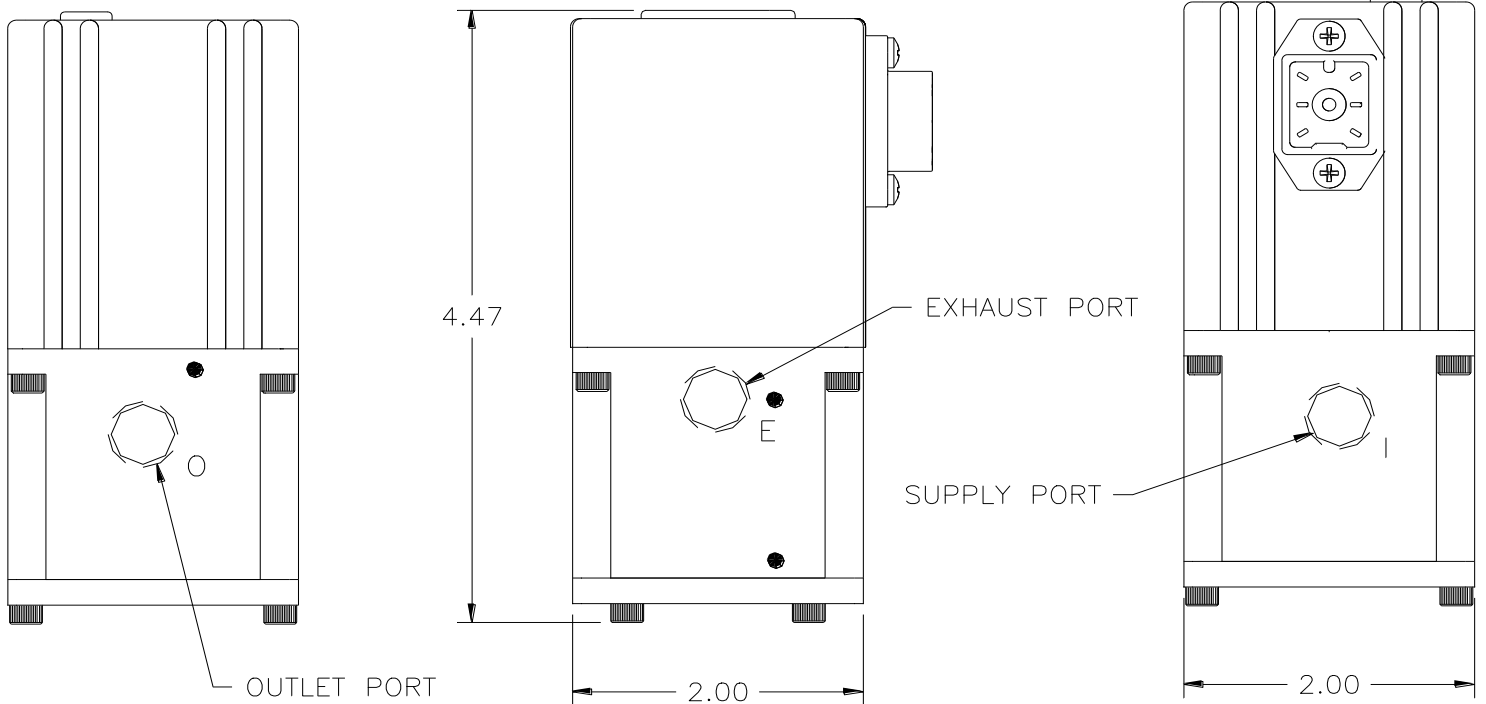

QB3

Example Part Number

ACCURACY	±0.25% F.S.	PRESSURE	Full Vac to 150 PSIG (10 Bar)
PORT SIZE	1/4"	MAX FLOW	30 SCFM (850 SLPM)
QB	3	T	A
	1	2	3
	4	5	6
	7	8	9
	10	11	OPTIONS

Section Reference

1	Type
1	-14.7 to 150 psi

2	Manifold Material
A	Nickel-Plated Aluminum
B	Nickel-Plated Brass*
*Includes O2 Cleaning	

4	Input Signal Range
E	0 to 10 VDC
I	4 to 20 mA DC
K	0 to 5 VDC
V	1 to 5 VDC*
N	Ethernet/Proportion-Air ¹
M	Ethernet/Modbus TCP ¹
A	RS232 Serial Input ¹
B	RS485 Serial Input ¹
P	P2 Profiler (Integrated)
*Requires V for Monitor Signal (#5)	
**Requires X for Monitor Signal (#5)	

3	Thread Type
N	NPT
P	BSP - CALL

5	Output Signal Range
X	No Monitor
E	0 to 10 VDC
K	0 to 5 VDC*
V	1 to 5 VDC ¹
C	4 to 20 mA DC (Sinking)
S	4 to 20 mA DC (Sourcing)
*Requires E, I or K for Input Signal Range (#4)	
**Requires V for Input Signal Range (#4)	

6	Zero Offset
N	0% Pressure is Below Zero
P	0% Pressure is Above Zero
Z	0% Pressure is Zero (Typical)

7	Zero Offset Pressure
Typical is 0% - If greater than 30% of full scale pressure (#9 below), please consult factory.	
*If Z for Zero Offset, Please Leave this Section (#7) Blank	

8	Full Scale Pressure Type
N	100% Pressure is Below Zero
P	100% Pressure is Above Zero
Z	100% Pressure is Zero

9	Full Scale Pressure
Must be less than or equal to 150 psig	

10	Pressure Unit (no additional fee - all)		
PS	PSI	Inches Hg	IH
MB	Millibars	Inches H ₂ O	IW
BR	Bar	Millimeters H ₂ O	MW
KP	Kilo-pascal	Kilograms/cm ²	KG
MP	Mega-pascal	Torr (Requires A for Unit of Measure #11)	TR
MH	Millimeters Hg	Centimeters H ₂ O	CW
PA	Pascal		

11	Pressure Unit of Measure
A	Absolute Pressure
G	Gauge Pressure

Recommended Accessories	
QBT-C-6	6 ft. Power/Command/Monitor Cable
QBT-01	Wrap-Around Mounting Bracket
QBT-03	Foot-Mount Bracket (Installed)*
* Use Option BR for Foot-Mount Bracket	

Safety Precautions



Please read all of the following Safety Precautions before installing or operating any Proportion-Air, Inc. equipment or accessories. To confirm safety, be sure to observe 'ISO 4414: Pneumatic Fluid Power - General rules relating to systems' and other safety practices.



Warning

Improper operation could result in serious injury to persons or loss of life!

- PRODUCT COMPATIBILITY**
Proportion-Air, Inc. products and accessories are for use in industrial pneumatic applications with compressed air media. The compatibility of the equipment is the responsibility of the end user. Product performance and safety are the responsibility of the person who determined the compatibility of the system. Also, this person is responsible for continuously reviewing the suitability of the products specified for the system, referencing the latest catalog, installation manual, Safety Precautions and all materials related to the product.
- EMERGENCY SHUTOFF**
Proportion-Air, Inc. products cannot be used as an emergency shutoff. A redundant safety system should be installed in the system to prevent serious injury or loss of life.
- EXPLOSIVE ATMOSPHERES**
Products and equipment should not be used where harmful, corrosive or explosive materials or gases are present. Unless certified, Proportion-Air, Inc. products cannot be used with flammable gases or in hazardous environments.
- AIR QUALITY**
Clean, dry air is not required for Proportion-Air, Inc. products. However, a 40 micron particulate filter is recommended to prevent solid contamination from entering the product.
- TEMPERATURE**
Products should be used with a media and ambient environment inside of the specified temperature range of 32°F to 158°F. Consult factory for expanded temperature ranges.
- OPERATION**
Only trained and certified personnel should operate electronic and pneumatic machinery and equipment. Electronics and pneumatics are very dangerous when handled incorrectly. All industry standard safety guidelines should be observed.
- SERVICE AND MAINTENANCE**
Service and maintenance of machinery and equipment should only be handled by trained and experienced operators. Inspection should only be performed after safety has been confirmed. Ensure all supply pressure has been exhausted and residual energy (compressed gas, springs, gravity, etc.) has been released in the entire system prior to removing equipment for service or maintenance.



Caution

Improper operation could result in serious injury to persons or damages to equipment!

- PNEUMATIC CONNECTION**
All pipes, pneumatic hose and tubing should be free of all contamination, debris and chips prior to installation. Flush pipes with compressed air to remove any loose particles.
- THREAD SEALANT**
To prevent product contamination, thread tape is not recommended. Instead, a non-migrating thread sealant is recommended for installation. Apply sealant a couple threads from the end of the pipe thread to prevent contamination.
- ELECTRICAL CONNECTION**
To prevent electronic damage, all electrical specifications should be reviewed and all electrical connections should be verified prior to operation.

Exemption from Liability

- Proportion-Air, Inc. is exempted from any damages resulting from any operations not contained within the catalogs and/or instruction manuals and operations outside the range of its product specifications.
- Proportion-Air, Inc. is exempted from any damage or loss whatsoever caused by malfunctions of its products when combined with other devices or software.
- Proportion-Air, Inc. and its employees shall be exempted from any damage or loss resulting from earthquakes, fire, third person actions, accidents, intentional or unintentional operator error, product misapplication or irregular operating conditions.
- Proportion-Air, Inc. and its employees shall be exempted from any damage or loss, either direct or indirect, including consequential damage or loss, claims, proceedings, demands, costs, expenses, judgments, awards, loss of profits or loss of chance and any other liability whatsoever including legal expenses and costs, which may be suffered or incurred, whether in tort (including negligence), contract, breach of statutory duty, equity or otherwise.

Warranty

Proportion-Air, Inc. products are warranted to the original purchaser only against defects in material or workmanship for one (1) year from the date of manufacture. The extent of Proportion-Air's liability under this warranty is limited to repair or replacement of the defective unit at Proportion-Air's option. Proportion-Air shall have no liability under this warranty where improper installation or filtration occurred.



CE (EMC) Compliant

Except for models having the following features: RS232, RS485, P2 Profiler and Digital Display